

TECHNICAL SERVICE BULLETIN

Part #:	RMS-06122019	Engine:	5.9L Rear Gear Train Housing
Date:	10/31/2013	Title:	Rear Gear Train Rear Main Seal Installation Instructions

Note: For 5.9L Rear Geartrain engines, the use of rear crankshaft seal installation kit, part number 4890833, is required.

- 1) Attach the portion of the Cummins tool #3164660 to the rear of the crankshaft as see in in Diagram #1.
- 2) Thread the installation tool onto the threaded shaft as seen in Diagram #2.
- 3) Hold the installation tool while turning the threaded shaft counterclockwise until the tool contacts the flywheel housing. (Refer to your Cummins installation manual.)

Diagram #1

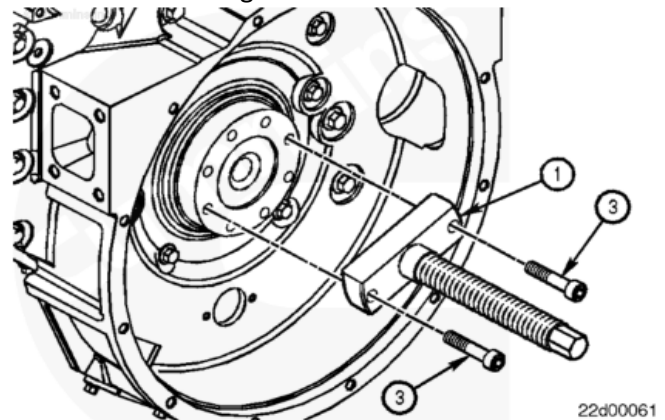
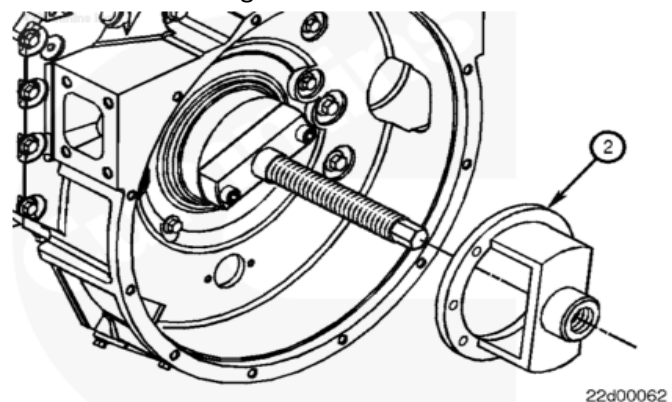

Diagram #2



Note: This seal kit has a built-in wear sleeve and a concealed sealing lip. The inner and outer diameters are press fit onto the crankshaft and flywheel housing respectively.

Diagram #3

