

## TECHNICAL SERVICE BULLETIN

Part #:	OPG-04142016	Engine:	6.0L & 6.4L Powerstroke; VT365
Date:	04/14/2016	Title:	Oil Pump Gear Set

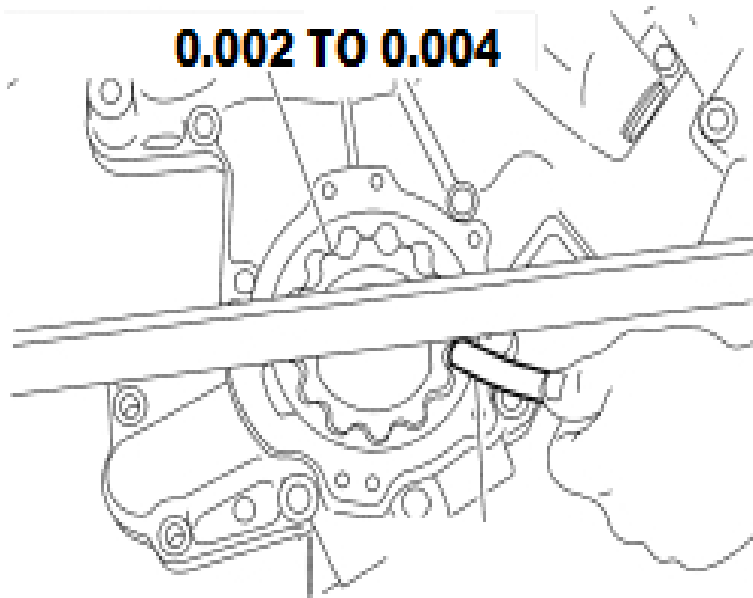

**BEFORE INSTALLING THE OIL PUMP HOUSING & ROTOR SET ON THE ENGINE. USING A STRAIGHT EDGE AND A FEELER GAUGE, MEASURE THE HEIGHT CLEARANCE BETWEEN THE OIL PUMP HOUSING AND THE INNER AND OUTER ROTOR. THE INNER AND OUTER ROTOR MUST BE 0.002 TO 0.004 BELOW THE OIL PUMP HOUSING.**

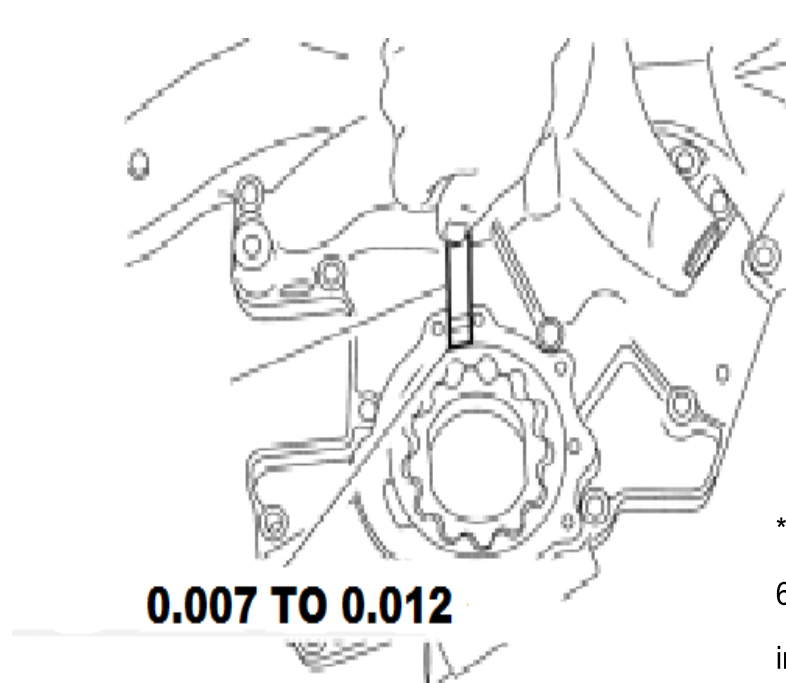

**INSTALL THE OIL PUMP HOUSING AND ROTOR SET ON THE ENGINE. USING A FEELER GAUGE, MEASURE THE CLEARANCE BETWEEN THE OUTER ROTOR AND THE OIL PUMP HOUSING. MEASURE AT 4 LOCATIONS, 90° FROM EACH OTHER. THE MEASUREMENT MUST BE BETWEEN 0.007 AND 0.012.**

\*Pictures are for reference only. The 6.0L and 6.4L components will vary slightly. But the installation process will remain the same.